

QDRHA-1000-2000-15-N

1~2GHz, 15dB, N

Features:
* Broadband

Applications:
* Wireless
* Transceiver
* Laboratory Test
* Broadcast

Electrical

Frequency: 1~2GHz
Gain: 15dB
VSWR: 1.5 max.

Mechanical

Size: 582.5*220.7*138.1mm
22.933*8.689*5.437in
Material: Aluminium
Connectors: N Female

How To Order

QDRHA-1000-2000-15-N

Customization is available upon request.

Outline Drawings

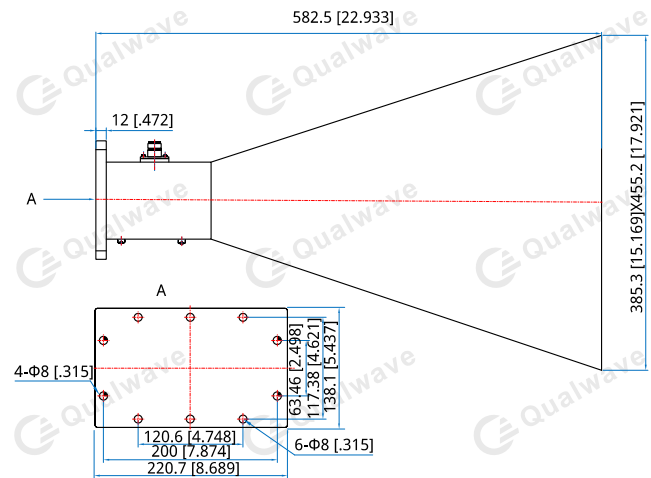

Unit: mm [in]

Tolerance: ± 0.2 mm [± 0.008 in]