

QDRHA-4750-11200-10-N

4.75~11.2GHz, 10dB, N

Features:
* Broadband

Applications:
* Wireless
* Transceiver
* Laboratory Test
* Broadcast

Electrical

Frequency:	4.75~11.2GHz
VSWR:	2.5 max.
Gain:	10dB
H Plane Beam Width:	36.15°~18.57°
E Plane Beam Width:	38.16°~18.93°

Mechanical

Connectors: N Female

Environmental

Non-operating Temperature: -10~+40°C

Outline Drawings

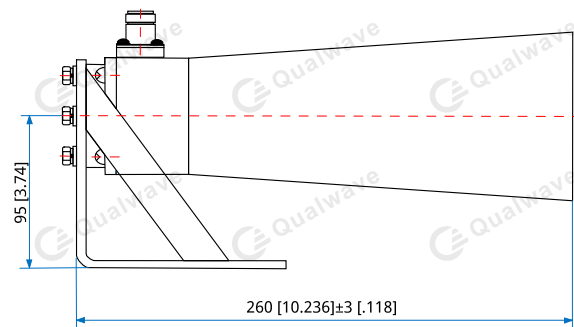

Unit: mm [in]

Tolerance: ±0.2mm [±0.008in]

How To Order

[QDRHA-4750-11200-10-N](#)

Customization is available upon request.