

QIMA-LA-PD2-1100-1700

1.1~1.7GHz

Features:
 * High Isolation
 * Low VSWR

Applications:
 * Wireless
 * Receiver
 * Laboratory Test
 * Communication

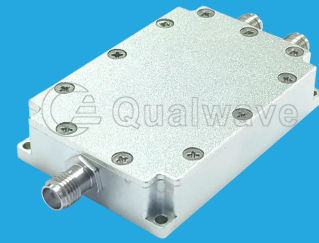

Description

QIMA-LA-PD2-1100-1700 is an integrated microwave assembly which amplifies RF signals and splits them into two output signals. Power supply can be applied at any port. DC block at any port can be applied on request.

Electrical

Frequency:	1.1~1.7GHz
Gain:	15dB typ.
Gain Flatness:	±0.5dB typ.
Output Isolation:	20dB typ.
Reverse Isolation:	30dB typ.
Output Power (P1dB):	+18dBm typ.
Noise Figure:	1.0dB typ.
Input VSWR:	1.5 typ.
Output VSWR:	1.2 typ.
Voltage:	+6~15V DC
Current:	700mA typ.
Impedance:	50Ω

Absolute Maximum Ratings*1

RF Input Power:	+22dBm
Voltage:	20V

[1] Permanent damage may occur if any of these limits are exceeded.

Mechanical

Size*2:	56*38*12mm 2.205*1.496*0.472in
Connector:	SMA Female

[2] Exclude connectors.

Typical Performance Curves

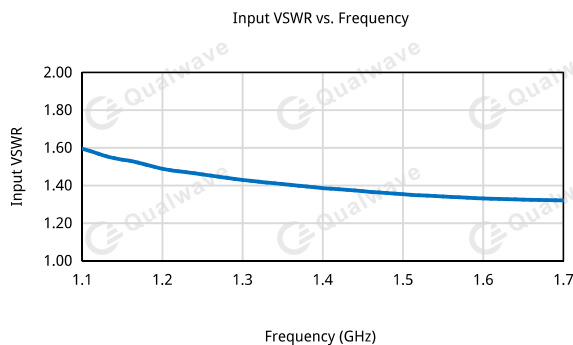

Environmental

Operating Temperature:	-35~+75°C
Non-operating Temperature:	-45~+85°C

Outline Drawings

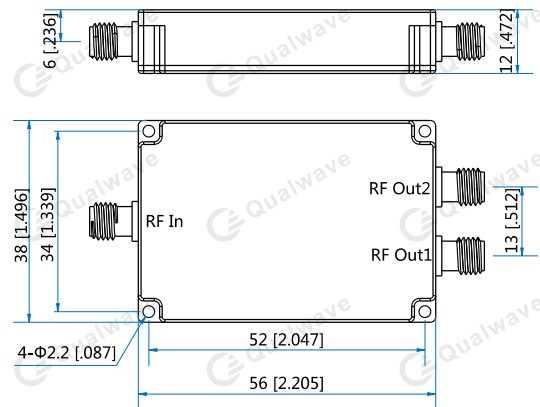

Unit: mm [in]
 Tolerance: ±0.5mm [±0.02in]

How To Order

QIMA-LA-PD2-1100-1700

Specify DC blocking port when placing the order. Customization is available upon request.

