

QLA-4000-8000-38-11

4~8GHz, 38dB, 1.1dB

Features:
 * Broadband
 * Low Noise

Applications:
 * Wireless
 * Receiver
 * Laboratory Test
 * Radar



Electrical

Frequency:	4~8GHz
Gain:	38dB typ.
Gain Flatness:	±1dB typ.
Output Power (P1dB):	18dBm min.
Noise Figure:	1.1dB typ.
Spurious:	-60dBc max.
VSWR:	1.6 typ.
Voltage:	+5V DC (Outline A) +6~15V DC (Outline B)
Current:	100mA typ.
Impedance:	50Ω

Absolute Maximum Ratings*1

RF Input Power:	+20dBm
Voltage:	+7V (Outline A) +20V (Outline B)

[1] Permanent damage may occur if any of these limits are exceeded.

Mechanical

RF Connectors: SMA Female

How To Order

QLA-4000-8000-38-11 - Outline A

QLA-4000-8000-38-11-1 - Outline B

Customization is available upon request.

Typical Performance Curves

Input VSWR vs. Frequency

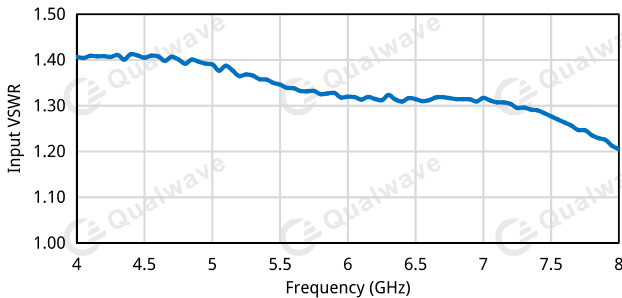

Output VSWR vs. Frequency

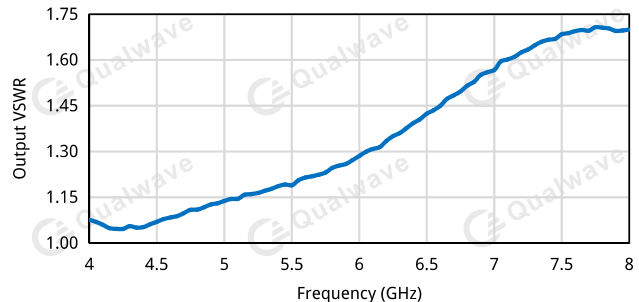

Environmental

Operating Temperature: -20~+60°C
 Non-operating Temperature: -40~+85°C

Outline Drawings

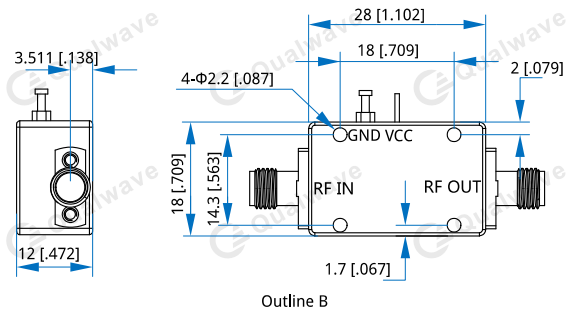
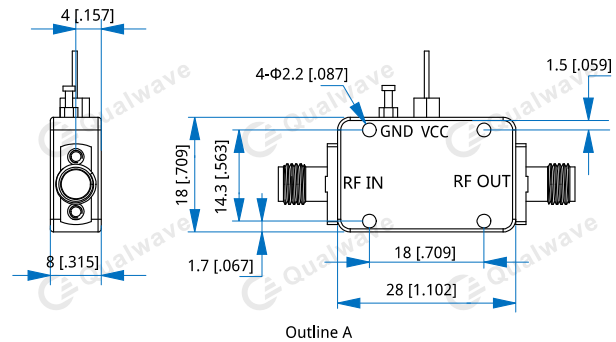

Unit: mm [in]
 Tolerance: ±0.5mm [±0.02in]

Gain vs. Frequency

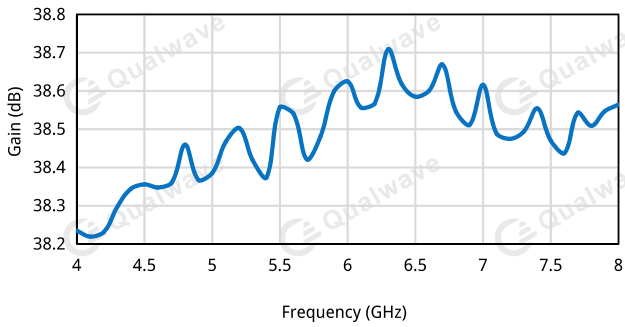

P1dB vs. Frequency

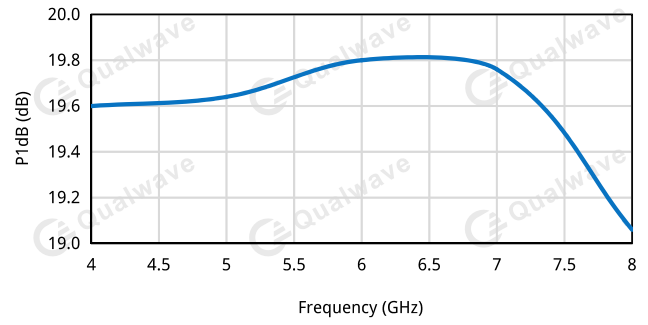

Noise Figure vs. Frequency

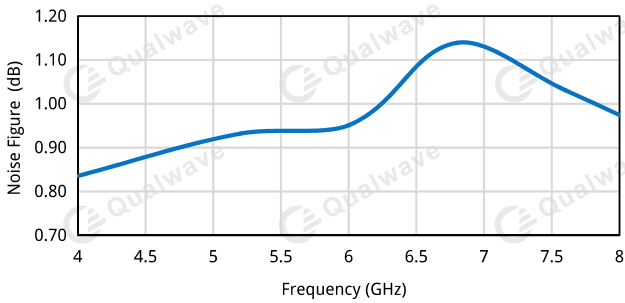

Isolation vs. Frequency

