

Enclosures

Features:

- * Small Size
- * Efficient Heat Dissipation
- * Sturdy & Shielded Construction

Applications:

- * Enclosure for assembling a compact amplifier
- * Housing for a power supply module

This document is intended to provide a systematic reference for the selection of enclosures for microwave devices. It summarizes various models of enclosure products, covering different specifications, dimensions, functional configurations, and installation methods to meet the needs of diverse application scenarios.

As the structural carrier of microwave devices, the enclosure serves the following core functions: providing physical protection and structural support, resisting external impact and dust ingress; establishing efficient heat dissipation paths to ensure long-term stable operation; and achieving electromagnetic shielding to reduce electromagnetic interference among internal components as well as intrusion from external signals.

Part Number	Description	Type	Size*1	Outline Drawings
0-000009	Universal chassis for LNA using AC-DC power supply	Desktop/Rack-mount	136*186*52mm 5.354*7.323*2.047in	Outline A
0-000006	Universal chassis for LNA using linear power supply	Desktop/Rack-mount	184.5*268*68mm 7.264*10.551*2.677in	Outline B
0-000007	Low-power amplifier enclosure	Desktop	288*250*98.6mm 11.339*9.843*3.882in	Outline C

[1] Exclude connectors, rack mount brackets, handles.

Outline Drawings

0-000009

Universal chassis for LNA using AC-DC power supply

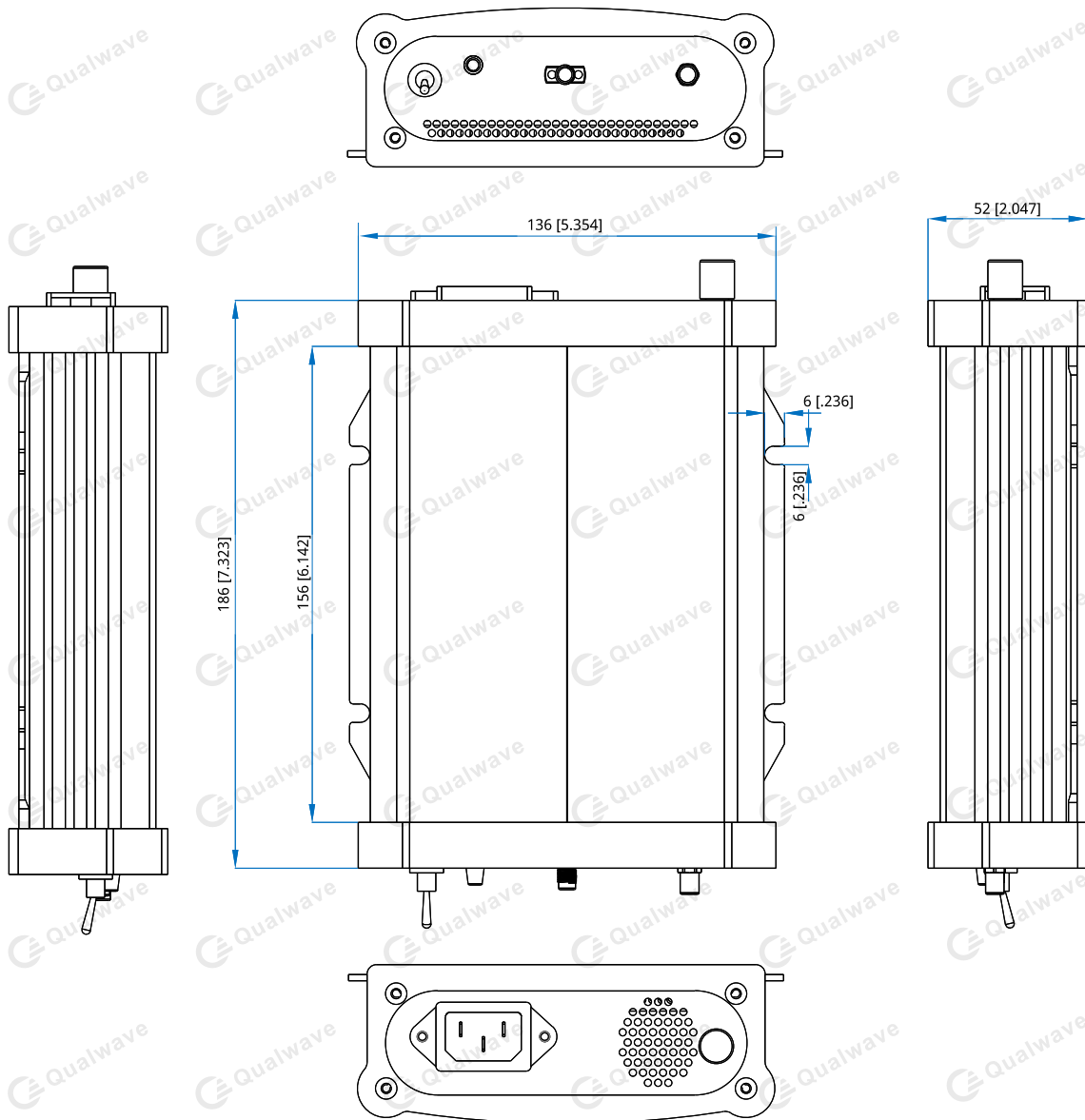

Outline A

0-000006

Universal chassis for LNA using linear power supply

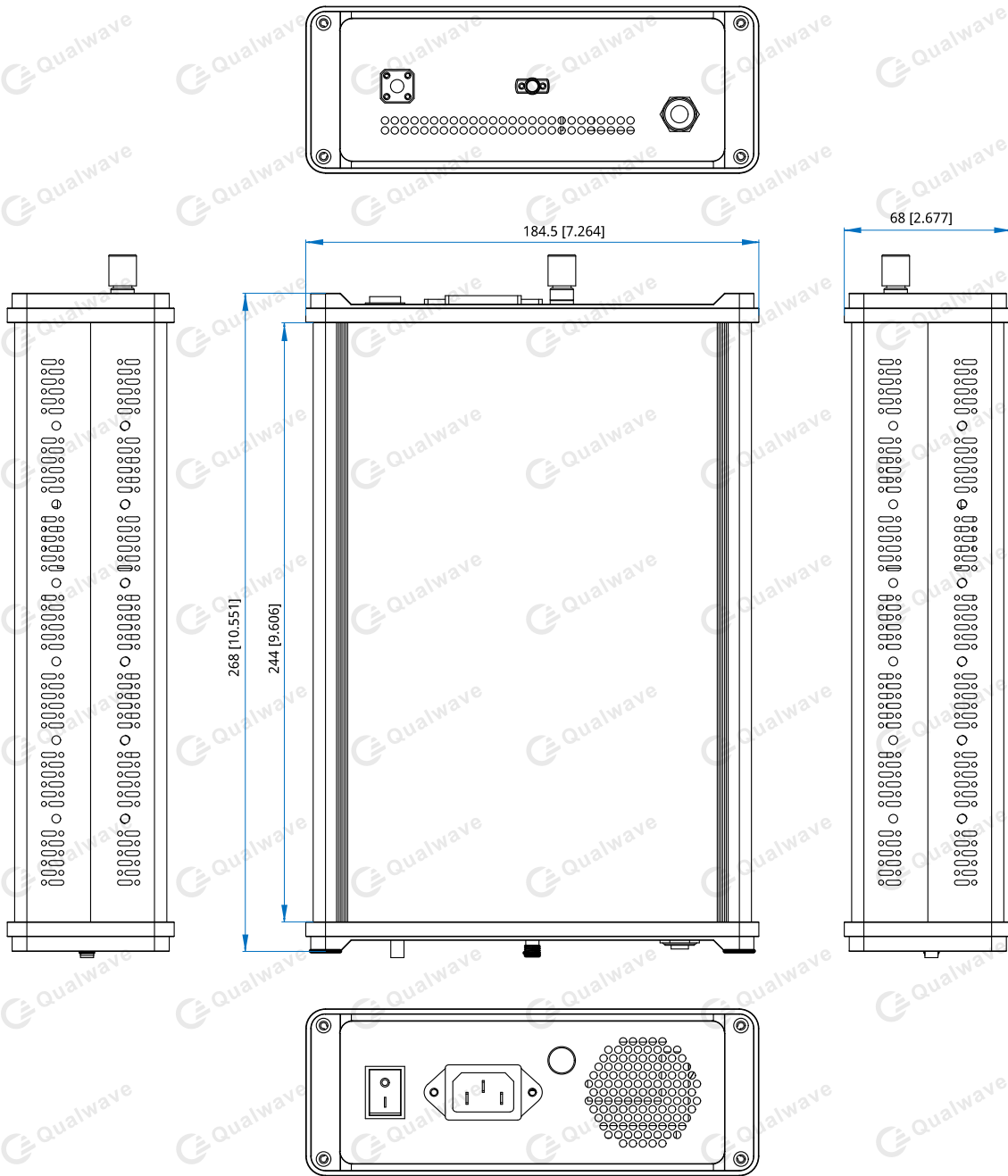

Outline B

0-000007

Low-power amplifier enclosure

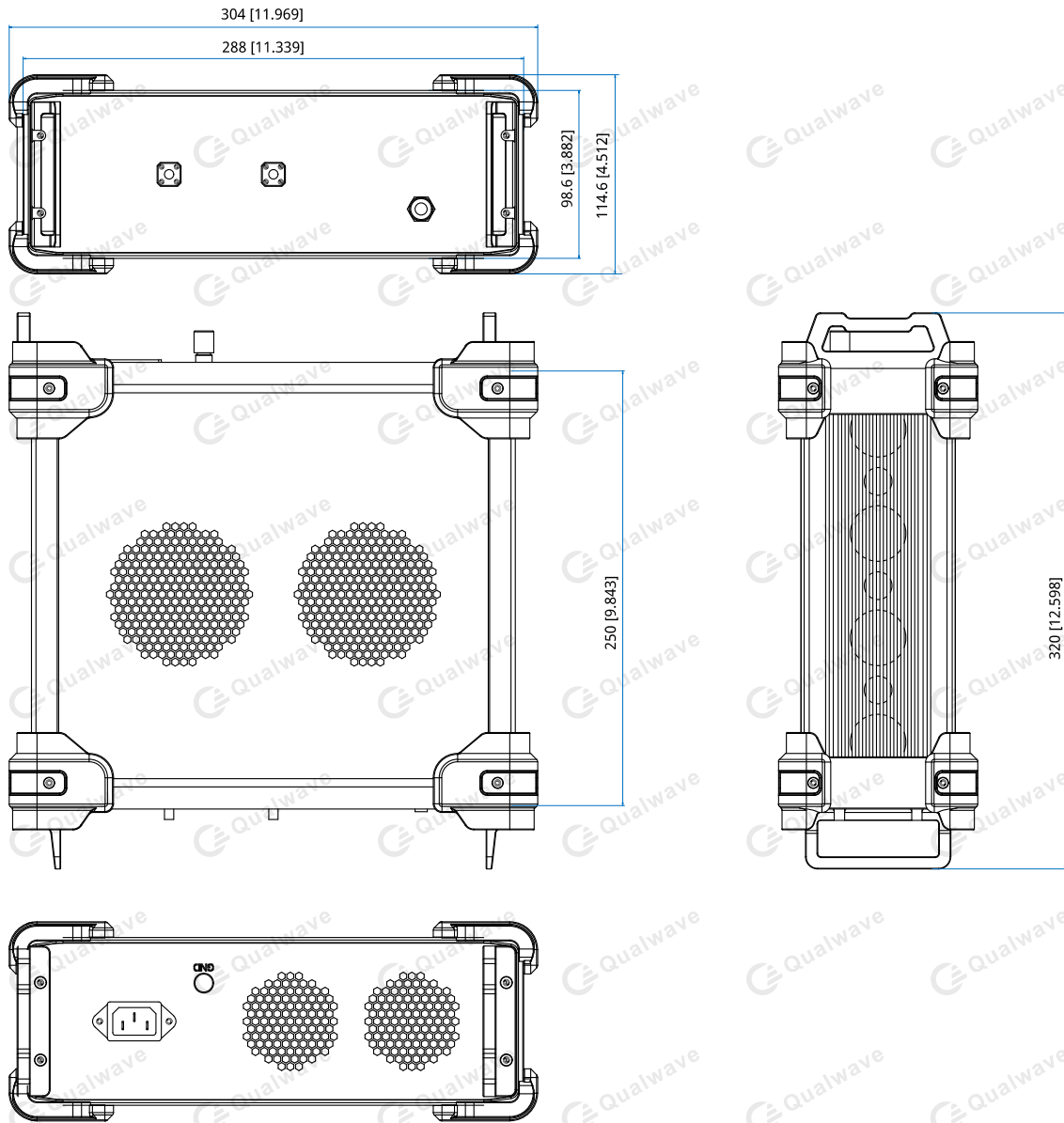

Outline C

Unit: mm [in]

 Tolerance: $\pm 0.2\text{mm}$ [$\pm 0.008\text{in}$]