

## QDRHA-1000-3000-N

1~3GHz, N

Features:  
\* Broadband

Applications:  
\* Wireless  
\* Transceiver  
\* Laboratory Test  
\* Broadcast

### Electrical

Frequency:	1~3GHz
VSWR:	2.5 max.
Gain:	6dBi min.
Polarization Method:	Linear
Impedance:	50Ω

### Mechanical

Size:	190*164.1*114.1mm 7.48*6.461*4.492in
Material:	Aluminium
Connectors:	N female

### How To Order

**QDRHA-1000-3000-N**

Customization is available upon request.

### Outline Drawings

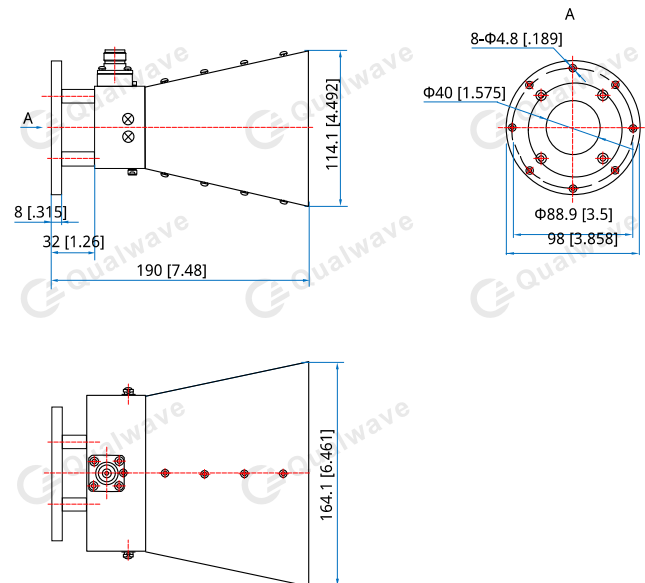

Unit: mm [in]  
Tolerance: ±0.2mm [±0.008in]