

QWCSD-112-N

DPDT, DC~10GHz, WR-112, N

Features:

- * Low VSWR
- * Low Insertion Loss
- * High Isolation

Applications:

- * Wireless
- * Transmitter
- * Laboratory Test
- * Radar

Electrical

Frequency(Coaxial):	DC~8.5GHz
Frequency(Waveguide):	7.05~10GHz
Current:	1.2A@24V DC
Voltage:	24±2V DC
Impedance:	50Ω

Coaxial Switch

Frequency range (GHz)	Insertion Loss (dB Max.)	Isolation (dB min.)	VSWR (Max.)
DC-1	0.05	80	1.1
1-2	0.1	70	1.15
2-6.5	0.25	60	1.25
6.5-8.5	0.3	60	1.3

Waveguide Switch

Frequency range (GHz)	Insertion Loss (dB Max.)	Isolation (dB min.)	VSWR (Max.)
7.05~10	0.05	60	1.08

Mechanical

Coaxial Switch Interface:	N
Waveguide Switch Interface:	WR-112
Switching Time:	80ms
Operation Life:	0.1M Cycles

Environmental

Operating Temperature:	-40~+85°C
Extended Temperature:	-55~+85°C
Non-operating temperature:	-55~+105°C

Outline Drawings

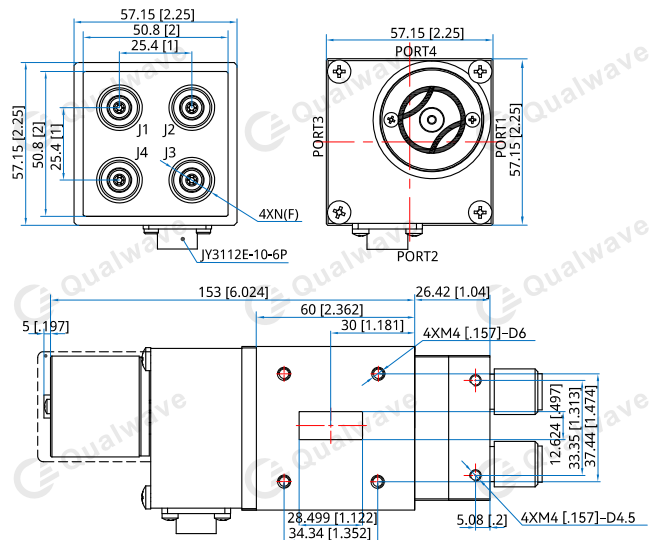

Unit: mm [in]
Tolerance: ±0.2mm [±0.008in]

Additional Options

- TTL: T
- Indicators: I
- Extended Temperature: Z

How To Order

QWCSD-112-N-XYZ

- S: RF Connectors. N: N.
- X: Voltage. +15V: F, +24V: K.
- Y: Interface Circular connector:2.
- Z: Additional Options.

Examples:

To order a Waveguide Coaxial Switch, DPDT, WR112, N, +24V, TTL, Indicators, specify QWCSD-112-N-K2IT.

Customization is available upon request.

Pin Numbering

Pin	Function	Pin	Function
A	VDC	D	Indicator1
B	GND	E	Indicator (COM)
C	VDC	F	Indicator2

Control Logic

Position	A	B	C	RF Working Condition	Indicator status
POS 1	VDC	GND	NC	PORT1-PORT2 ON PORT3-PORT4 ON	J1-J2 ON J3-J4 ON D-E ON F-E OPEN
POS 2	NC	GND	VDC	PORT1-PORT4 ON PORT3-PORT2 ON	J1-J4 ON J3-J2 ON D-E OPEN F-E ON

Driving Schematic Diagram

