

# QWSS-430-1000-A-2-1

## WR-430

Features:  
 \* Low VSWR  
 \* High Isolation

Applications:  
 \* Wireless  
 \* Transmitter  
 \* Laboratory Test  
 \* Radar

### Electrical

Frequency: 1.72~2.61GHz  
 VSWR: 1.1 max.  
 Insertion Loss: 0.1dB max.

### Mechanical

Interface: WR-430 (BJ22)  
 Flange: FDP22  
 Length: 1000mm  
 Material: Aluminum  
 Surface Treatment: Conductive oxidation  
 Coating: Black paint

### Outline Drawings

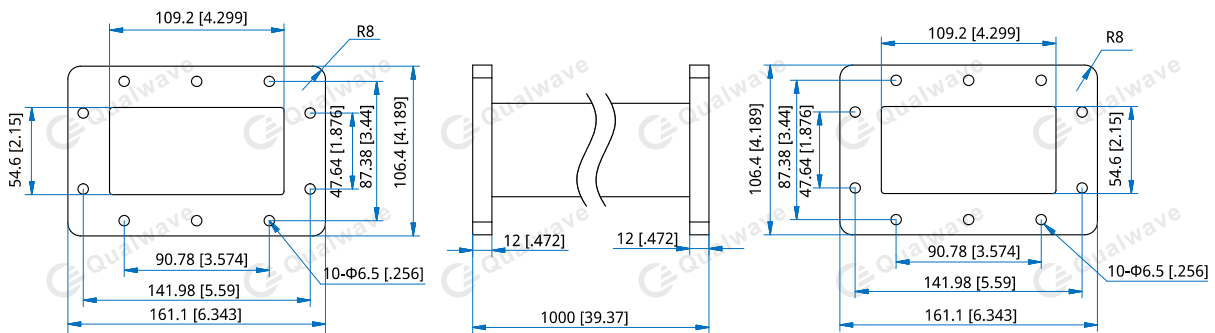

Unit: mm [in]

Tolerance:  $\pm 0.2\text{mm}$  [ $\pm 0.008\text{in}$ ]

### How To Order

**QWSS-430-1000-A-2-1**

Customization is available upon request.